

NAME: _____ ()

CLASS: _____



FAIRFIELD METHODIST SCHOOL (SECONDARY)

END-OF-YEAR EXAMINATION 2015
SECONDARY 2 EXPRESS

MATHEMATICS

Paper 1

Date: 07 October 2015

Duration: 1 hour 30 minutes

Candidates answer on the Question Paper.

READ THESE INSTRUCTIONS FIRST

Write your name, index number and class on all the work you hand in.

Write in dark blue or black pen.

You may use a pencil for any diagrams or graphs.

Do not use staples, paper clips, highlighters, glue or correction fluid.

Answer **all** questions.

If working is needed for any question it must be shown with the answer.

Omission of essential working will result in loss of marks.

You are expected to use a scientific calculator to evaluate explicit numerical expressions.

If the degree of accuracy is not specified in the question, and if the answer is not exact, give the answer to three significant figures. Give answers in degrees to one decimal place.

For π , use either your calculator value or 3.142, unless the question requires the answer in terms of π .

At the end of the examination, fasten all your work securely together.

The number of marks is given in brackets [] at the end of each question or part question.

The total number of marks for this paper is 60.

For Examiner's Use	
Paper 1	/ 60
Paper 2	/ 60
Total	%

Setter: Miss Germaine J Peter

120

This question paper consists of 15 printed pages including the cover page.

Name: _____ ()

Class: _____

Answer all the questions.

1 Arrange the following numbers in ascending order.

$\frac{1}{3}$

40%

$\sqrt[3]{-8}$

$\frac{2}{7}$

0.3

Answer,,,, [1]

2 Estimate the value of $\frac{11.835 \times 6.051}{\sqrt{17}}$, without the use of a calculator.

Answer [2]

3 The length of each side of a square, of length x cm, is increased by 20%. Find the percentage increase in the area of the square.

Answer% [2]

Name: _____ () Class: _____

- 4 (a) Express 1008 as a product of its prime factors, giving your answer in index notation.

Answer (a) [1]

- (b) Given that $1350 = 2 \times 3^3 \times 5^2$, find the lowest common multiple of 1008 and 1350, giving your answer in index notation.

Answer (b) [1]

- (c) Given that $\frac{1350}{k}$ is a square number, write down the smallest possible integer value of k .

Answer (c) $k =$ [1]

121

Name: _____ () Class: _____

5 The force of attraction, F newtons, between two magnets is inversely proportional to the square of the distance, x centimetres, between them.

It is given that when the magnets are 4 centimetres apart, the force is 3 newtons.

(a) Find an equation connecting F and x .

Answer (a) [1]

(b) Find the force when the magnets are 2 centimetres apart.

Answer (b)newtons [1]

(c) When the magnets are a certain distance apart, the force is 1.25 newtons. Write down the force when the distance is halved.

Answer (c) newtons [2]

- 6 The diagram shows a right-angled triangle in a circle, with centre O .
 Given that the diameter of the circle is 14 cm, find the length of AB .

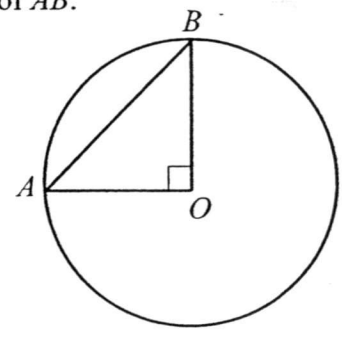

Answercm [2]

- 7 A closed cylindrical container has a radius of 6.8 cm and a volume of 1500 cm^3 .
 [Take π to be 3.142]

- (a) Show that the height of the cylindrical container is 10.3 cm.

Answer (a) [2]

- (b) Find the surface area of the cylindrical container.

Answer (b) cm^2 [2]
 122

Name: _____ ()

Class: _____

8 The diagram below shows a point Q with coordinates $(2, r)$.

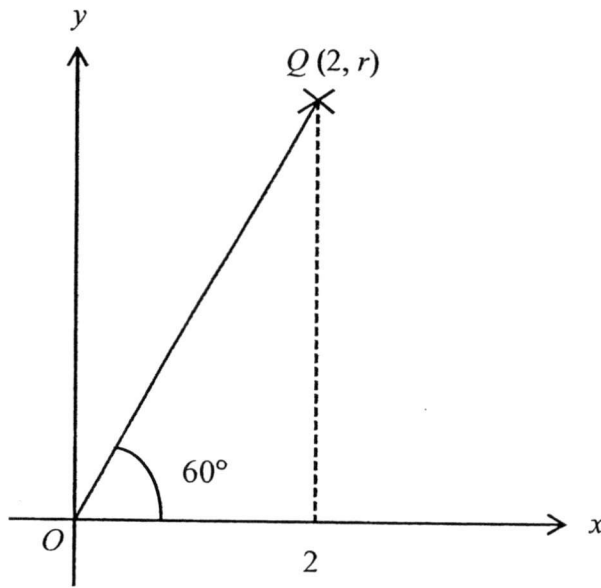

(i) Find the length of OQ .

Answer (i) $OQ = \dots\dots\dots$ cm [2]

(ii) Find the value of r .

Answer (ii) $r = \dots\dots\dots$ [2]

Name: _____ ()

Class: _____

9 Simplify the following expressions.

(a) $\frac{3a^2}{7bc} \div \frac{9a}{14b}$

Answer (a) [2]

(b) $\frac{2x}{x^2-25} - \frac{1}{x-5}$

Answer (b) [3]

123

Name: _____ () Class: _____

- 10 Petrol costs x cents per litre. John intends to take a road trip during the holidays.
Find an expression for the number of litres of petrol that can be bought for y dollars.

Answer1 [2]

- 11 A sum of money is divided between Alice, Betty and Charlie in the ratio 2 : 3 : 4 respectively. If, instead, this money had been divided equally between them, Alice would have received an extra \$20.

What was the total sum of money given to Alice, Betty and Charlie?

Answer \$..... [2]

12 The graph below shows the lines $-x+2y=2$ and $2x+2y=5$.

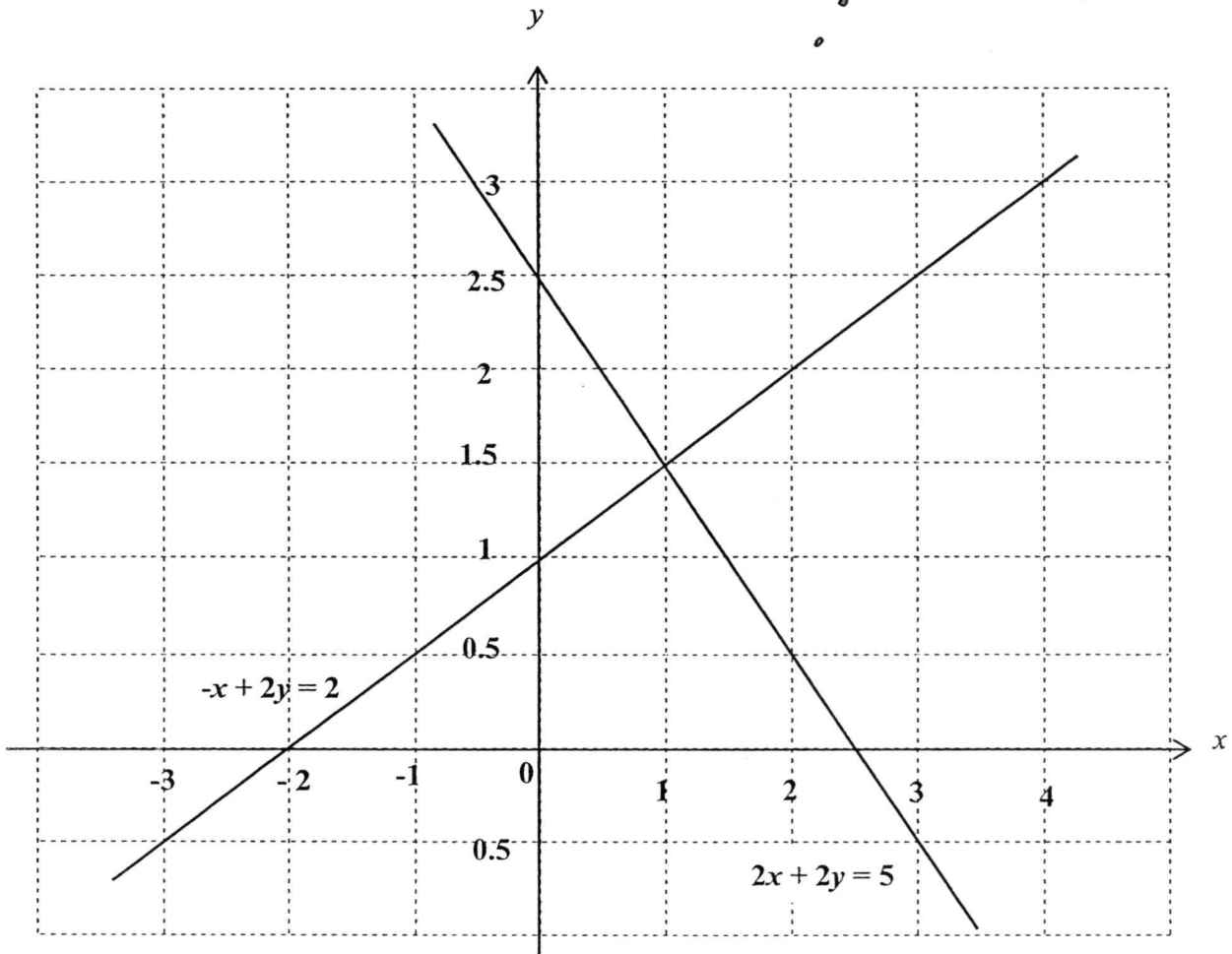

(a) State the solution of the simultaneous equations $-x+2y=2$ and $2x+2y=5$.

Answer (a) $x = \dots\dots\dots y = \dots\dots\dots$ [1]

(b) On the same grid above, draw and label clearly the line $x=3$. [1]

(c) Find the area of the polygon enclosed by the 3 lines, $-x+2y=2$, $2x+2y=5$ and $x=3$. Leave your answer in square units.

Answer (c) $\dots\dots\dots$ units² [1]
12/4

Name: _____ ()

Class: _____

13 In the figure, ABC and DBE are similar triangles, where $\angle ACB = \angle DEB$.

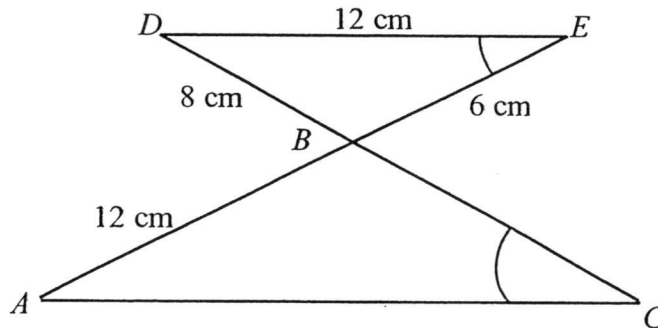

Find

(a) the length of AC ,

Answer (a)cm [2]

(b) the length of CD .

Answer (b)cm [2]

Name: _____ ()

Class: _____

14 Factorise fully each of the following expressions completely.

(a) $3p^2 - 3pq - 5ap + 5aq$

Answer (a) [2]

(b) $6x^2 + 14x - 12$

Answer (b) [2]

15 A bag contains 10 red marbles, 5 blue marbles and 3 yellow marbles.

(a) Find the probability that the marble is red.

Answer (a) [1]

(b) How many more blue marbles must be placed in the bag so that the probability of choosing a blue marble would be $\frac{1}{2}$?

Answer (b)blue marbles [1]

125

Name: _____ ()

Class: _____

16 Solve the equation $\frac{5}{y-3} + \frac{10}{3(3-y)} = 3$.

Answer $y = \dots\dots\dots$ [3]

Name: _____ () Class: _____

17 Solve the following simultaneous equations.

$$4a + 15b = 15$$

$$7a - 30b = 15$$

Answer $a = \dots\dots\dots, b = \dots\dots\dots$ [3]

126

Name: _____ ()

Class: _____

- 18 The following stem and leaf diagram represents the marks obtained by 10 boys and 10 girls in a Mathematics test.

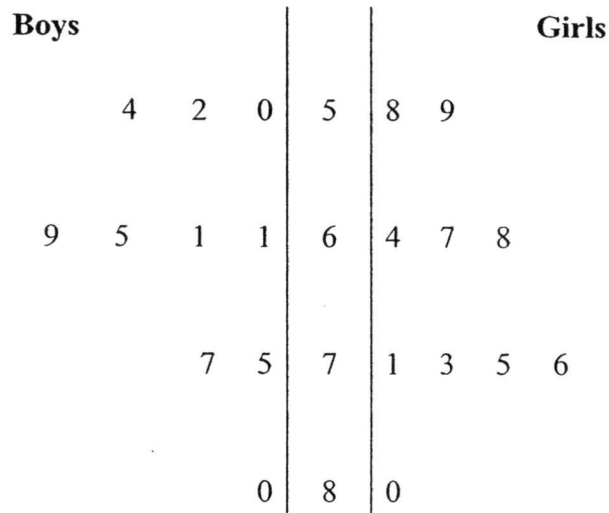

Key (Boys): 2|5 means 52

Key (Girls): 5|8 means 58

From the data above, find

- (a) (i) the mode of the boys' marks,

Answer (a)(i).....marks [1]

- (ii) the median of the girls' marks,

Answer (a)(ii).....marks [1]

- (iii) the mean of the boys' marks.

Answer (a)(iii).....marks [1]

- (b) Given that the mean of the girls' marks is 69.1, explain briefly whether the boys or girls performed better in the test.

Answer (b) [1]

.....
.....

- 19 (a) Construct the perpendicular bisector of BC . [1]
 (b) Construct the bisector of $\angle ABC$. [1]
 (c) The point D is such that $\angle BCD = 130^\circ$ and $AD = 7.5$ cm.
 Find the two possible positions of D and label them D_1 and D_2 . [2]
 (d) It is given that the two bisectors in (a) and (b) meet at P . [2]
Complete the statement below.

The point P is equidistant from the lines and
 and equidistant from the points and

Answer (a), (b), (c)

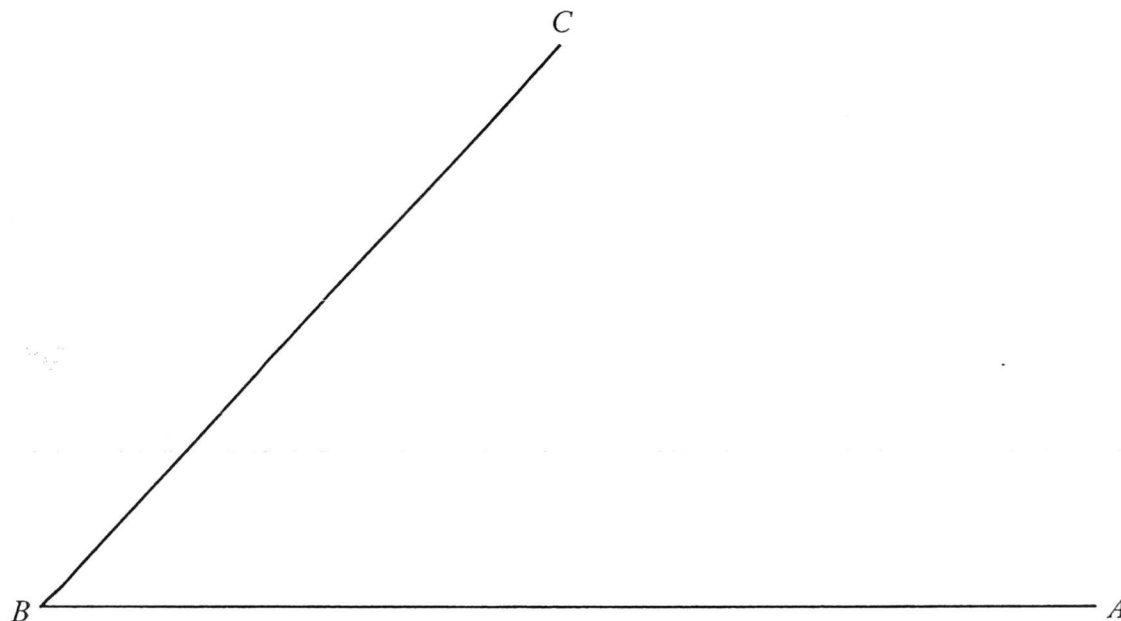



Name: _____ ()

Class: _____

Fairfield Methodist School (Secondary)
Sec 2 Express 2015 EOY Examination
Mathematics Paper 1
Answer Key

No.	Answer	No.	Answer
1	$\sqrt[3]{-8}, \frac{2}{7}, 0.3, \frac{1}{3}, 40\%$	17	$a = 3$ $b = \frac{1}{5}$
2	18	18ai	61 marks
3	44%	18aii	69.5 marks
4a	$1008 = 2^4 \times 3^2 \times 7$	18aiii	64.4 marks
4b	$\text{LCM} = 2^4 \times 3^3 \times 5^2 \times 7$	19a	Refer to M.S
4c	$k = 6$	19b	Refer to M.S
5a	$F = \frac{48}{x^2}$	19c	Refer to M.S
5b	$F = 12$ newtons	19d	BA, BC ; B,C
5c	$F = 5$ newtons		
6	$AB = 9.90$		
7a	10.3		
7b	732 cm^2 or 731 cm^2		
8i	$OQ = 4$		
8ii	$h = 3.46$		
9a	$\frac{2a}{3c}$		
9b	$\frac{1}{x+5}$		
10	$\frac{100y}{x}$		
11	\$180		
12a	$x = 1, y = 1.5$		
12c	3 units ²		
13a	$AC = 18 \text{ cm}$		
13b	$CD = 17 \text{ cm}$		
14a	$(3p - 5a)(p - q)$		
14b	$2(3x - 2)(x + 3)$		
15a	$\frac{5}{9}$		
15b	8 more		
16	$3\frac{5}{9}$		



Sec 2 Express 2015
EOY Examination
Mathematics Paper 1 Marking Scheme

No.	Working	Allocation of marks	
1	$\sqrt[3]{-8}, \frac{2}{7}, 0.3, \frac{1}{3}, 40\%$	[B1] no mark if answer is not according to question	
2	$\frac{11.835 \times 6.051}{\sqrt{17}}$ $\approx \frac{12 \times 6}{\sqrt{16}}$ $= \frac{72}{4}$ $= 18$	[M1] [A1]	
3	Percentage increase = $\frac{(1.2x)^2 - x^2}{x^2} \times 100$ $= 44\%$	[M1] [A1]	
4a	$1008 = 2^4 \times 3^2 \times 7$	[B1]	
4b	$\text{LCM} = 2^4 \times 3^3 \times 5^2 \times 7$	[B1]	
4c	$k = 2 \times 3 = 6$	[B1]	
5a	$F = \frac{k}{x^2}$ $3 = \frac{k}{4^2}$ $k = 3 \times 16$ $F = \frac{48}{x^2}$	[B1]	
5b	$F = \frac{48}{2^2}$ $F = 12 \text{ newtons}$	No F.T. mark [B1]	
5c	$1.25 = \frac{k}{x^2}$ $F = \frac{k}{\left(\frac{x}{2}\right)^2} = \frac{4k}{x^2}$ $\therefore F = 1.25 \times 4$ $= 5$	When $k = 48$, $1.25 = \frac{48}{x^2}$ $F = \frac{48}{\left(\frac{x}{2}\right)^2}$ $F = 4 \left(\frac{48}{x^2} \right)$ $F = 1.25 \times 4$ $= 5$	[M1] [A1]

6	By Pythagoras' Theorem, $AB = \sqrt{\left(\frac{14}{2}\right)^2 + \left(\frac{14}{2}\right)^2}$ $AB = 7\sqrt{2} \text{ or } AB = 9.90 \text{ (to 3sf) (since length } > 0)$	[M1] [A1]	
7a	$\pi r^2 h = 1500$ $h = \frac{1500}{3.142 \times 6.8^2}$ $= 10.3244$ $= 10.3 \text{ (to 3sf)}$	[M1] [A1]	
7b	$2\pi r^2 + 2\pi rh$ $= 2(3.142)(6.8^2)$ $+ 2(3.142)(6.8)(10.3244)$ $= 731.746$ $= 732 \text{ cm}^2 \text{ (to 3sf)}$	If h = 10.3 used, $2\pi r^2 + 2\pi rh$ $= 2(3.142)(6.8^2)$ $+ 2(3.142)(6.8)(10.3)$ $= 731.285$ $= 731 \text{ cm}^2 \text{ (to 3sf)}$	[M1] [A1]
8i	$\cos 60^\circ = \frac{2}{OQ}$ $\therefore OQ = 4$ $\text{or } OQ = 4.00(3sf)$	$\sin 30^\circ = \frac{2}{OQ}$ $\therefore OQ = 4$ $\text{or } OQ = 4.00(3sf)$	[M1] [A1]
8ii	$r = \sqrt{4^2 - 2^2}$ $r = 2\sqrt{3}$ $\text{Or } 3.464$ $= 3.46 \text{ (to 3 sf)}$	$\tan 60^\circ = \frac{r}{2}$ $\therefore r = 3.464$ $= 3.46 \text{ (to 3 sf)}$	[M1] [A1]
9a	$\frac{3a^2}{7bc} \div \frac{9a}{14b}$ $= \frac{3a^2}{7bc} \times \frac{14b}{9a}$ $= \frac{2a}{3c}$	[M1] for reciprocal of term after division sign [A1]	
9b	$\frac{2x}{x^2 - 25} - \frac{1}{x - 5}$ $= \frac{2x - (x + 5)}{x^2 - 25}$ $= \frac{x - 5}{x^2 - 25}$ $a = 2$	[M1] for making 2 nd term have the same denominator [M1] for change of sign [A1]	
10	$y \text{ dollars} = 100y \text{ cents}$	[M1]	

	$\frac{100y}{x}$ Amount of petrol = $\frac{100y}{x}$	[A1]
11°	Total number of units = $2+3+4 = 9$ If equally divided among A, B and C, each will get 3 units Therefore total sum of money = $(3-2) \times 9 \times \$20$ = \$180	[M1] [A1]
12a	$x = 1, y = 1.5$	[B1]
12 b	Line drawn at $x = 3$	[B1]
12c	Area = $\frac{1}{2} \times 6 \times 2$ = 6 units ²	[B1]
13a	$\frac{12}{8} = \frac{AC}{12}$ $AC = \frac{144}{8} = 18cm$	[M1] [A1]
13b	$\frac{CB}{6} = \frac{12}{8}$ $CB = 9$ $\therefore CD = 8 + 9 = 17cm$	[M1] [A1]
14a	$3p^2 - 3pq - 5ap + 5aq$ $= 3p(p-q) - 5a(p-q)$ $= (3p-5a)(p-q)$	[M1] [A1]
14b	$6x^2 + 14x - 12$ $= 2(3x^2 + 7x - 6)$ $= 2(3x-2)(x+3)$	[B1] for factor 2 [B1] for factors in brackets
15a	Total no. of balls = 18 Probability that ball is red = $\frac{10}{18} = \frac{5}{9}$	[B1]
15b	Let additional blue marbles be x . $\frac{5+x}{18+x} = \frac{1}{2}$ $18+x = 10+2x$ $x = 8$	[B1]

16	$\frac{5}{y-3} + \frac{10}{3(3-y)} = 3$ $\frac{5}{y-3} - \frac{10}{3(y-3)} = 3$ $\frac{5}{3(y-3)} = 3$ $5 = 9y - 27$ $y = \frac{32}{9}$ $= 3\frac{5}{9}$	<p>[M4] for change of sign</p> <p>[M1] for multiplying denominator to both sides and correct expansion</p> <p>[A1] marks awarded if improper fraction</p>
17	$4a + 15b = 15$ $7a - 30b = 15$ <p>(1) x 2: $8a + 30b = 30$ ---(3)</p> <p>(2) + (3): $15a = 45$</p> <p>$a = 3$ Sub ($a = 3$) into (1): $4(3) + 15b = 15$ $15b = 15 - 12$</p> $b = \frac{1}{5}$	<p>[M1] for elimination or substitution method</p> <p>[A1]</p> <p>[A1]</p>
18ai	Modal marks = 61 marks	[B1]
18aii	Median current = $\frac{68+71}{2}$ = 69.5marks	[B1]
18aiii	Mean of boys' marks = $\frac{50+52+54+2(61)+65+69+75+77+80}{10}$ = 64.4marks	[B1]
18b	<u>Sample Answer:</u> The girls preformed better. Because they attained a higher mean score as compared to the boys	*definitely is girls [B1]
19d	BA, BC ; B,C	[B1] [B1]

Qn 19a, b, c

Marking Scheme.
Answer (a), (b), (c)

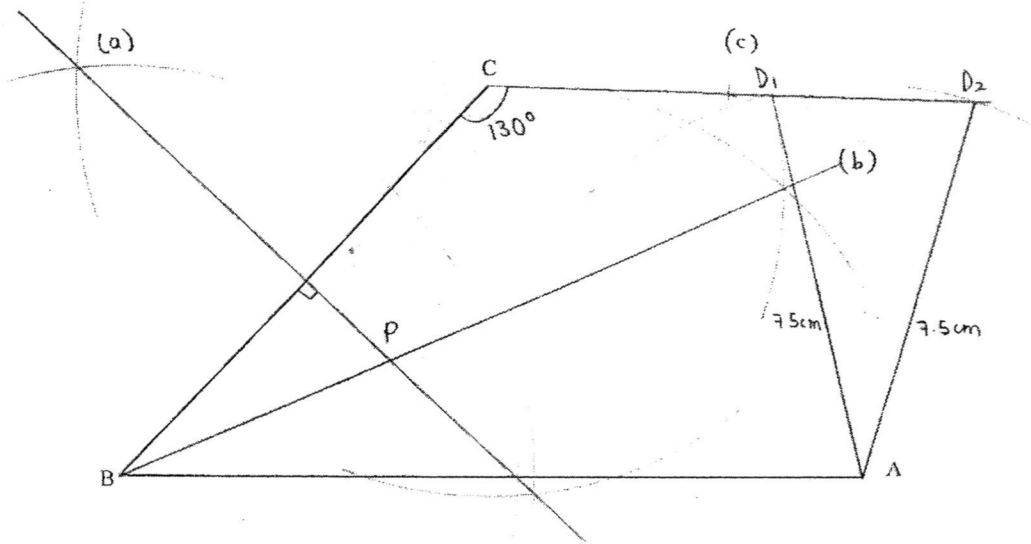

NAME: _____ ()

CLASS: _____



FAIRFIELD METHODIST SCHOOL (SECONDARY)

END-OF-YEAR EXAMINATION 2015
SECONDARY 2 EXPRESS

MATHEMATICS

Paper 2

Date: 08 October 2015

Duration: 1 hour 30 minutes

Candidates answer on Question Paper.

Additional Material : Graph paper (1 sheet)

READ THESE INSTRUCTIONS FIRST

Write your name, index number and class on all the work you hand in.

Write in dark blue or black pen.

You may use a pencil for any diagrams or graphs.

Do not use staples, paper clips, highlighters, glue or correction fluid.

Answer **all** questions.

If working is needed for any question it must be shown with the answer.

Omission of essential working will result in loss of marks.

Calculators should be used where appropriate.

If the degree of accuracy is not specified in the question, and if the answer is not exact, give the answer to three significant figures. Give answers in degrees to one decimal place.

For π , use either your calculator value or 3.142, unless the question requires the answer in terms of π .

At the end of the examination, fasten all your work securely together.

The number of marks is given in brackets [] at the end of each question or part question.

The total number of marks for this paper is 60.

At the end of the examination, fasten all your work securely together.

For Examiner's Use	
Paper 2	/ 60

Setter: Miss Michelle Tan

This question paper consists of 16 printed pages including the cover page.

Name : _____ ()

Sec 2__

Answer **all** the questions.

1. The ratio of the length and breadth of a rectangle is 5 : 3. Given that the perimeter of the rectangle is 32 cm, find the length of the rectangle.

Answer cm [1]

2. Mdm Teo bought 48 apples, 72 oranges and 96 pears. If she wants each type of fruit to be distributed equally among a certain number of fruit baskets, what is the greatest number of fruit baskets that can be prepared?

Answerfruit baskets [2]

3. If y is directly proportional to x^3 and the difference in the values of y when $x = 1$ and $x = 2$ is 35, find the value of y when $x = -3$.

Answer [2]

4. (a) Calculate the sum of the interior angles of a decagon.

Answer (a).....° [1]

- (b) Seven of the interior angles of a decagon are 165° each. The rest of the angles are $2x^\circ$, $(2x + 15)^\circ$ and $(x - 30)^\circ$. Find the value of the largest interior angle.

Answer (b).....° [2]

132

Name : _____ ()

Sec 2__

5. Jennifer sold x cupcakes at 60 cents each and 32 cookies at 20 cents each during a fund raising activity in school. At the end of the day, she received at least \$168.

(a) Write down an inequality in x to represent the information given above.

Answer (a)..... [1]

(b) Solve the inequality formed in (a).

Answer (b)..... [1]

(c) Hence, find the minimum number of cupcakes sold.

Answer (c).....cupcakes [1]

6. Study the number pattern below.

	C_1	C_2	C_3	C_4
R_1	2	4	8	64
R_2	3	5	15	225
R_3	4	6	24	576
R_4	5	7	35	1225
R_5	6	8	48	2304
\vdots	\vdots	\vdots	\vdots	\vdots
R_n	$n + 1$	$n + 3$	575	330625
R_{n+1}	w	x	y	z

(a) Write down an expression for w , x and y in terms of n .

Answer (a) $w = \dots\dots\dots$

$x = \dots\dots\dots$

$y = \dots\dots\dots$ [1]

(b) (i) Form an equation in terms of n .

Answer (b)..... [1]

(b) (ii) Show that your answer in (b)(i) can be simplified to $n^2 + 4n - 572 = 0$.

Answer (b)(ii) [1]

(c) Explain why the number 15000 would not appear in the column C_4 .

Answer (c)

..... [1]

(d) Write down an expression for z in terms of y .

Answer (d) $z = \dots\dots\dots$ [1]

Name : _____ ()

Sec 2__

7. (a) Given that $\sqrt[3]{\frac{1-x}{y}} = p$, express x in terms of p and y .

Answer (a)..... [2]

(b) Hence, find the value of x when $p = -1$ and $y = 6$.

Answer (b)..... [1]

8. It is given that $a^2 + b^2 = 548$ and $2ab = 352$ and $a > b$, find the value of $a^2 - b^2$ where a and b are positive integers.

Answer [3]

Name : _____ ()

Sec 2__

9. Expand and simplify the following expressions.

(a) $-3x(2x - 5)$

Answer (a)..... [1]

(b) $7(x - 4) - 3(2x + 4)$

Answer (b)..... [2]

10. (a) Factorise $3k(4 - h) - (h - 4)$.

Answer (a)..... [1]

(b) Hence, simplify $\frac{3k(4 - h) - (h - 4)}{16 - h^2}$

Answer (b)..... [2]

134

Name : _____ ()

Sec 2__

11. Solve the following equations.

(a) $x - (2x - 8) = 28 + 4x$

Answer (a) $x = \dots\dots\dots$ [2]

(b) $(m - 20)^2 = 144$

Answer (b) $m = \dots\dots\dots$ or $\dots\dots\dots$ [2]

12. A map of Sentosa Island in Singapore is drawn to a scale of 1 : 50000.

- (a) The distance on the map between the Merlion Park and Tanjong Beach is 3.6 cm. Calculate, in kilometers, the actual distance between these two places.

Answer (a).....km [1]

- (b) Sentosa Island has an actual area of 5 km². Calculate in square centimeters, the area of Sentosa Island on the map.

Answer (b).....cm² [2]

13. The figure shows a vertical monument AB . Caine is standing on a platform 5.7 m away, at point C .

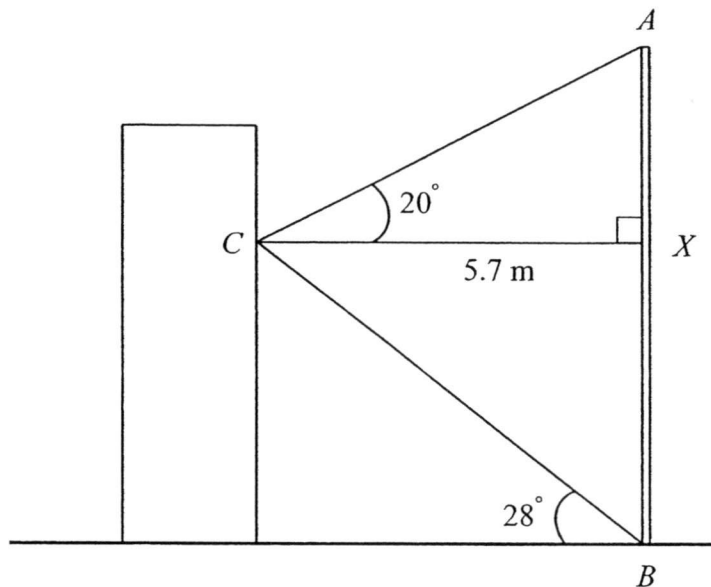

It is given that the angle of elevation from C to the top of the monument is 20° and the angle of elevation from the foot of the monument to C is 28° . Find the height of the monument.

Answer..... m [3]

14. The table shows the number of hours, h , spent by a group of 20 students on the computer in a week.

5	2	14	8	17	0	11	3	9	20
3	10	12	22	14	20	18	20	12	24

(a) Complete the frequency table for the data.

[1]

No. of hours	Frequency
$0 \leq h < 5$	4
$5 \leq h < 10$	
$10 \leq h < 15$	
$15 \leq h < 20$	
$20 \leq h < 25$	

(b) Draw a histogram to illustrate the data in (a).

[2]

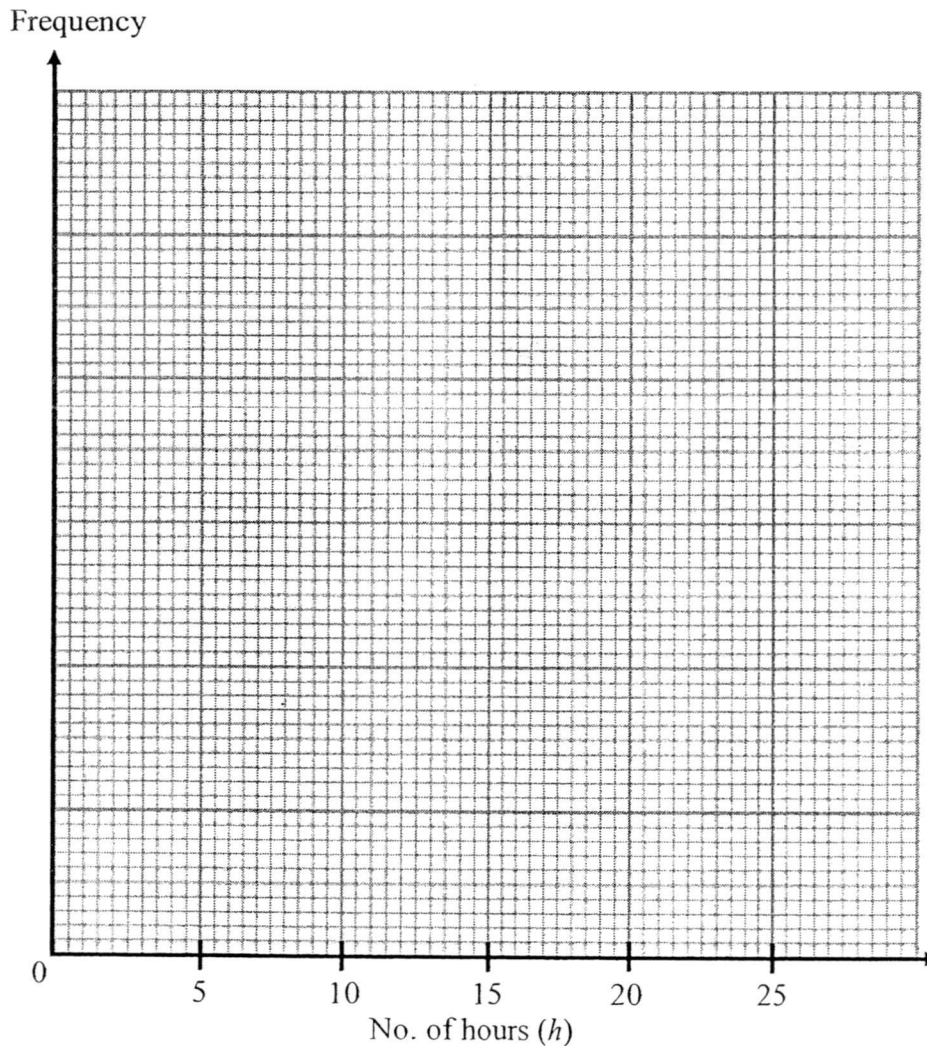

136

Name : _____ ()

Sec 2__

14. (c) Calculate an estimated mean for the number of hours the group of students spent on the computer in a week.

Answer (c)..... [2]

15. A metal ornament is made up of a pyramid with a rectangular cuboid as its base as shown in the diagram below.

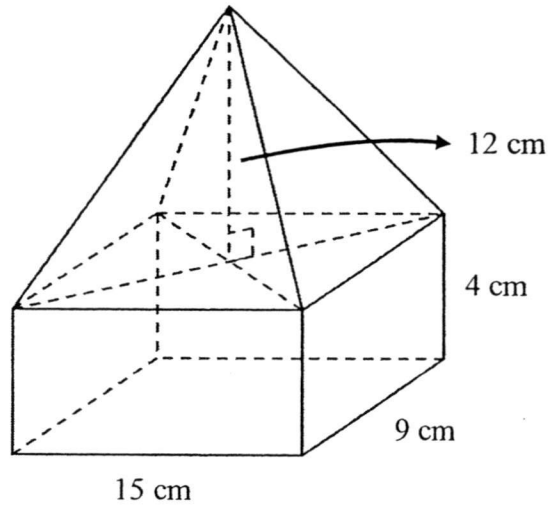

- (a) It is given that the height of the pyramid is 12 cm and the dimensions of the cuboid is 15 cm by 9 cm by 4 cm.
- (i) Find the volume of the pyramid.

Answer (a)(i).....cm³ [2]

- (ii) Show that the volume of the metal ornament is 1080 cm³.

Answer (a)(ii) [1]

Name : _____ ()

Sec 2__

15. (b) The metal ornament was melted and recast into smaller solid cones with a base circumference of 12 cm and a slant height of 5 cm. Take $\pi = 3.142$.

(i) Find the volume of each cone.

Answer (b)(i).....cm³ [3]

(ii) Hence, find the maximum number of cones that can be formed.

Answer (b)(ii).....cones [1]

15. (c) An engineer then cut off the top of the cone with a vertical height of 2 cm and a diameter of 1 cm. He intends to paint the remaining of the ornament after the removal of the top of the cone.

(i) Find the curved surface area of the remaining ornament after the removal of the top of the cone.

Answer (c)(i).....cm² [2]

(ii) Find the total surface area of the ornament to be painted.

Answer (c)(ii).....cm² [2]

16. Answer the whole of this question on a sheet of graph paper.

The variables x and y are connected by the equation $y = x^2 - 8x + 7$. The table below shows the corresponding values of x and y for the equation.

x	0	2	3	4	5	6
y	7	-5	-8	p	-8	-5

- (a) Calculate the value of p . [1]
- (b) Taking 2 cm to represent 1 unit on the x -axis and 1 cm to represent 1 unit on the y -axis, draw the graph of $y = x^2 - 8x + 7$ for $0 \leq x \leq 6$. [3]
- (c) Using your graph, solve $x^2 - 8x + 7 = -4$. [1]
- (d) State the equation of the line of symmetry of the graph. [1]

~ End of Paper ~



Name : _____ ()

Sec 2__

1	10 cm	14b													
2	24														
3	-135														
4a	1440°														
4b	165°														
5a	$60x + 32(20) \geq 16800$ or $0.6x + 32(0.2) \geq 168$														
5b	$x \geq 269\frac{1}{3}$														
5c	270														
6a	$w = n + 2, x = n + 4, y = (n + 2)(n + 4)$														
6bi	$(n + 1)(n + 3) = 575$														
6bii	$(n + 1)(n + 3) = 575$ $n^2 + 4n + 3 = 575$ $n^2 + 4n - 572 = 0$ (shown)														
6c	The numbers in C_4 are all perfect squares. Since 15000 is not a perfect square, it will not appear in C_4 .														
6d	$z = y^2$														
7a	$x = 1 - yp^3$			14c	12.75										
7b	$x = 1 - 6(-1)^3 = 7$	15ai	540 cm^3												
8	420	15aii	Volume of ornament = $540 + (15 \times 9 \times 4) = 1080 \text{ cm}^3$ (shown)												
9a	$-6x^2 + 15x$	15bi	17.6 cm^3												
9b	$x - 40$	15bii	61												
10a	$(4 - h)(3k + 1)$ or $(h - 4)(-3k - 1)$ or $-(-4 + h)(3k + 1)$	15ci	27.6 cm^2 (used int. values to 5sf) or 26.8 cm^2 (used exact int. values)												
10b	$\frac{3k + 1}{4 + h}$	15cii	40.4 cm^2 (used int. values to 5sf) or 39.0 cm^2 (used exact int. values)												
11a	$x = -4$	16a	$p = -9$												
11b	$m = 32$ or $m = 8$	16b													
12a	1.8km														
12b	20 cm^2														
13	5.11 m														
14a	<table border="1"> <thead> <tr> <th>No. of hours</th> <th>Frequency</th> </tr> </thead> <tbody> <tr> <td>$0 \leq h < 5$</td> <td>4</td> </tr> <tr> <td>$5 \leq h < 10$</td> <td>3</td> </tr> <tr> <td>$10 \leq h < 15$</td> <td>6</td> </tr> <tr> <td>$15 \leq h < 20$</td> <td>2</td> </tr> <tr> <td>$20 \leq h < 25$</td> <td>5</td> </tr> </tbody> </table>	No. of hours		Frequency	$0 \leq h < 5$	4	$5 \leq h < 10$	3	$10 \leq h < 15$	6	$15 \leq h < 20$	2	$20 \leq h < 25$	5	
No. of hours	Frequency														
$0 \leq h < 5$	4														
$5 \leq h < 10$	3														
$10 \leq h < 15$	6														
$15 \leq h < 20$	2														
$20 \leq h < 25$	5														

Name : _____ ()

Sec 2__

		16c	Accept $x= 1.7$ to 1.8
		16d	$x= 4$



FMS(S) Sec 2 Express EOY 2015
Mathematics Paper 2 Marking Scheme

1.	Length of rectangle = $\frac{32}{16} \times 5 = 10$ cm [B1]
2.	$48 = 2^4 \times 3$ $72 = 2^3 \times 3^2$ $96 = 2^5 \times 3$ HCF = $2^3 \times 3$ [M1] = 24 [A1]
3.	$y = kx^3$ When $x = 1, y = k$ When $x = 2, y = 8k$ $8k - k = 35$ $7k = 35$ $k = 5$ [M1] When $x = -3,$ $y = 5(-3)^3 = -135$ [A1]
4a.	$(10 - 2) \times 180^\circ = 1440^\circ$ [B1]
4b.	$7(165) + 2x + (2x + 15) + (x - 30) = 1440$ $5x = 300$ $x = 60$ [M1] Largest interior angle = 165° [A1]
5a.	$60x + 32(20) \geq 16800$ [B1] or $0.6x + 32(0.2) \geq 168$ [B1]
5b.	$60x + 32(20) \geq 16800$ $60x \geq 16160$ $x \geq 269\frac{1}{3}$ (to 5sf) [B1]
5c.	270 [B1]
6a.	$w = n + 2, x = n + 4, y = (n + 2)(n + 4)$ [B1]
6bi.	$(n + 1)(n + 3) = 575$ [B1]
6bii.	$(n + 1)(n + 3) = 575$ $n^2 + 4n + 3 = 575$ $n^2 + 4n - 572 = 0$ (shown) [B1]
6c.	The numbers in C_4 are all perfect squares. Since 15000 is not a perfect square, it will not appear in C_4 . [B1]
6d.	$z = y^2$ [B1]

FMS(S) Sec 2 Express EOY 2015
 Mathematics Paper 2 Marking Scheme

7a.	$\sqrt[3]{\frac{1-x}{y}} = p$ $\frac{1-x}{y} = p^3 \text{ [M1]}$ $1-x = yp^3$ $x = 1 - yp^3 \text{ [A1]}$
7b.	$x = 1 - 6(-1)^3 = 7 \text{ [B1]}$
8.	$a^2 + b^2 + 2ab = 548 + 352$ $(a+b)^2 = 900$ $a+b = 30 \text{ [M1]}$ $a^2 + b^2 - 2ab = 548 - 352$ $(a-b)^2 = 196$ $a-b = 14 \text{ [M1]}$ $a^2 - b^2 = (a+b)(a-b)$ $= 30(14)$ $= 420 \text{ [A1]}$
9a	$-6x^2 + 15x \text{ [B1]}$
9b	$7(x-4) - 3(2x+4)$ $= 7x - 28 - 6x - 12 \text{ [M1 for } -12]$ $= x - 40 \text{ [A1]}$
10a.	$3k(4-h) - (h-4)$ $= 3k(4-h) + (4-h)$ $= (4-h)(3k+1) \text{ [B1] accept } (h-4)(-3k-1) \text{ and } -(-4+h)(3k+1)$
10b.	$\frac{3k(4-h) - (h-4)}{16-h^2}$ $= \frac{(4-h)(3k+1)}{(4-h)(4+h)} \text{ [M1 for factorising denominator]}$ $= \frac{3k+1}{4+h} \text{ [A1]}$
11a.	$x - (2x-8) = 28 + 4x$ $x - 2x + 8 = 28 + 4x \text{ [M1 for } +8]$ $-5x = 20$ $x = -4 \text{ [A1]}$

<p>11b.</p>	<p>$(m - 20)^2 = 144$ $m - 20 = 12$ or $m - 20 = -12$ [M1] $m = 32$ or $m = 8$ [A1]</p> <p>Or</p> <p>$(m - 20)^2 = 144$ $m^2 - 2(m)(20) + 20^2 = 144$ $m^2 - 40m + 256 = 0$ $(m - 8)(m - 32) = 0$ [M1 for factorisation] $m - 8 = 0$ or $m - 32 = 0$ $m = 32$ or $m = 8$ [A1]</p>
<p>12a.</p>	<p><u>Map</u> <u>Actual</u> 1 cm rep. 50000 cm 3.6 cm rep. 180000 cm = 1.8km [B1]</p>
<p>12b.</p>	<p><u>Actual</u> <u>Map</u> 50000 cm rep. 1 cm 0.5km rep. 1 cm 0.25km² rep. 1 cm² [M1] 5km² rep. 20 cm² [A1]</p>
<p>13.</p>	<p>$\angle ACX = 28^\circ$ (alt. angles) $\tan 28^\circ = \frac{BX}{5.7}$ $BX = 3.0307$ m (to 5 sf) [M1] $\tan 20^\circ = \frac{AX}{5.7}$ $AX = 2.0746$ m (to 5 sf) [M1] Height of monument = $3.0307 + 2.0746 = 5.11$ m (to 3sf) [A1]</p> <p>Or</p> <p>$\angle XBC = 62^\circ$ $\tan 62^\circ = \frac{5.7}{BX}$ $BX = 3.0307$ m (to 5 sf) [M1] $\tan 70^\circ = \frac{5.7}{AX}$ $AX = 2.0746$ m (to 5 sf) [M1] Height of monument = $3.0307 + 2.0746 = 5.11$ m (to 3sf) [A1]</p>

14a.

No. of hours	Frequency
$0 \leq h < 5$	4
$5 \leq h < 10$	3
$10 \leq h < 15$	6
$15 \leq h < 20$	2
$20 \leq h < 25$	5

[B1 for all correct]

14b.

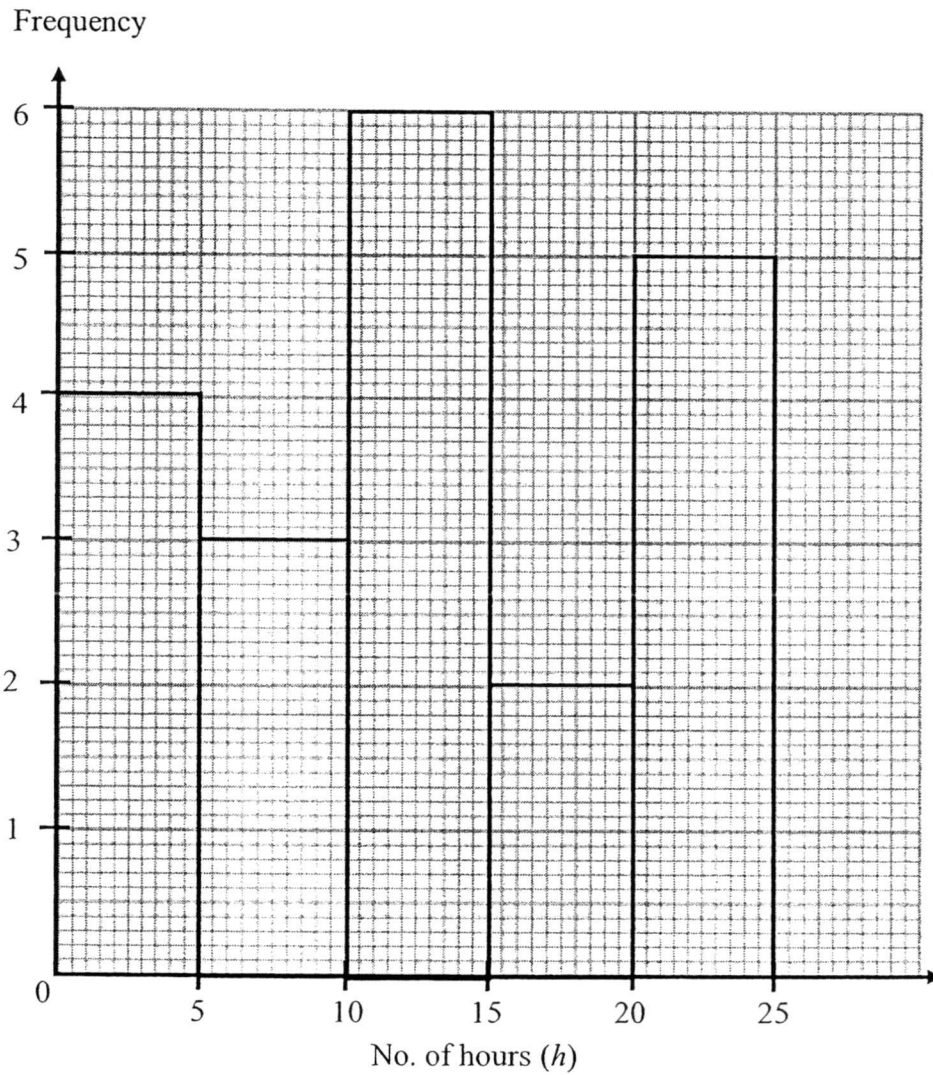

[B2] for all heights of bars drawn correctly [No FT mark]

[B1] for 2 or less error in height of bars

[No marks if 3 or more errors]

14c.	Estimated mean = $\frac{(2.5 \times 4) + (7.5 \times 3) + (12.5 \times 6) + (17.5 \times 2) + (22.5 \times 5)}{20}$ [M1] $= \frac{255}{20}$ $= 12.75$ [A1]
15ai.	Volume of pyramid = $\frac{1}{3} \times 15 \times 9 \times 12$ [M1] $= 540 \text{ cm}^3$ [A1]
15aii.	Volume of ornament = $540 + (15 \times 9 \times 4) = 1080 \text{ cm}^3$ (shown) [B1]
15bi.	Radius of base = $\frac{12}{3.142} \div 2 = 1.9096 \text{ cm}$ [M1 for radius or height] Height of cone = $\sqrt{5^2 - 1.9096^2} = 4.6210 \text{ cm}$ Volume of cone = $\frac{1}{3} \times 3.142 \times 1.9096^2 \times 4.6210$ [M1] $= 17.648 \text{ cm}^3$ (to 5 sf) $= 17.6 \text{ cm}^3$ (to 3 sf) [A1]
15bii.	Max. no. of cones = $1080 \div 17.648 = 61.196 = 61$ (nearest whole number) [B1]
15ci.	Slant height of removed part = $\sqrt{2^2 + 0.5^2}$ $= \sqrt{4.25}$ $= 2.0616$ (to 5sf) Remaining curved surface area $= (3.142 \times 1.9606 \times 5) - (3.142 \times 0.5 \times 2.0616)$ [M1] $= 27.562 \text{ cm}^2$ (to 5sf) $= 27.6 \text{ cm}^2$ (to 3sf) [A1] Or Remaining curved surface area $= (3.142 \times \left[\frac{12}{3.142} \div 2 \right] \times 5) - (3.142 \times 0.5 \times \sqrt{4.25})$ [M1] $= 26.761 \text{ cm}^2$ (to 5sf) $= 26.8 \text{ cm}^2$ (to 3sf) [A1]

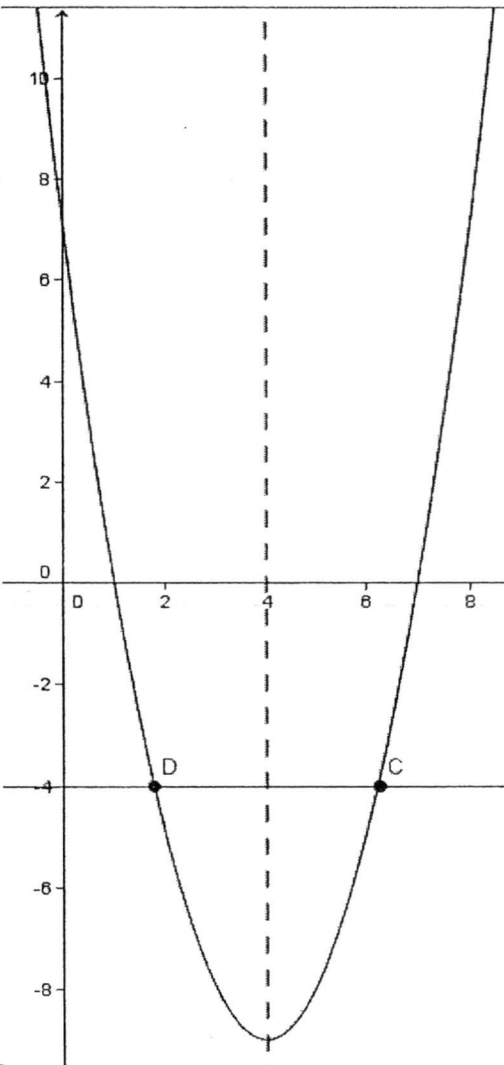
<p>15cii.</p>	<p>Total surface area to be painted $= 27.562 + (3.142 \times 0.5^2) + (3.142 \times 1.9606^2)$ [M1] $= 40.425 \text{ cm}^2$ (to 5sf) $= 40.4 \text{ cm}^2$ (to 3sf) [A1]</p> <p>Or</p> <p>Total surface area to be painted $= 26.761 + (3.142 \times 0.5^2) + (3.142 \times \left[\frac{12}{3.142} \div 2 \right]^2)$ [M1 for addition of 3 parts] $= 39.004 \text{ cm}^2$ (to 5sf) $= 39.0 \text{ cm}^2$ (to 3sf) [A1]</p>
<p>16a.</p>	<p>$p = -9$ [B1]</p>
<p>16b.</p>	<div style="display: flex; align-items: center;">  <div style="margin-left: 20px;"> <p>P: 2 C: 1 (smooth curve)</p> <p>[Minus 1 mark for no label of axis or curve]</p> </div> </div>
<p>16c.</p>	<p>$x = 0.4, 7.6$ (+/- 0.1) [B1]</p>
<p>16d.</p>	<p>$x = 4$ [B1]</p>